

## Appendix B PCB Layouts

Description	page
1. Padding Capacitor 160&80m. . . . .	2
2. Central Processor Unit. . . . .	4
3. HV Power Supply . . . . .	6
4. Input Board . . . . .	8
5. Keyboard. . . . .	10
6. Mains&LV Power Supply . . . . .	12
7. True Resistance Indicator. . . . .	14
8. Wattmeter. . . . .	16

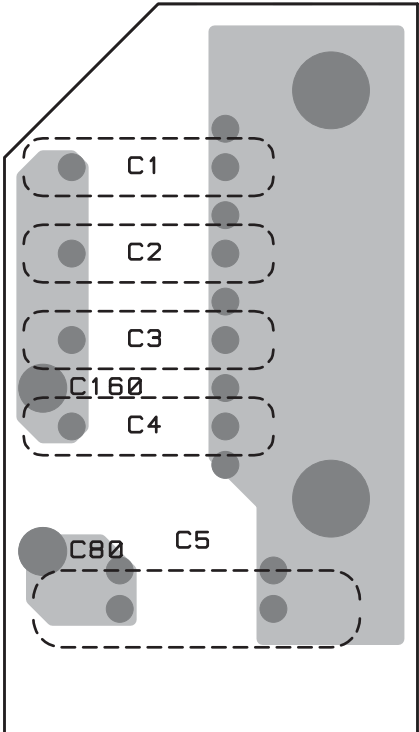

**PADDING CAPACITOR 160&80m  
Component side**

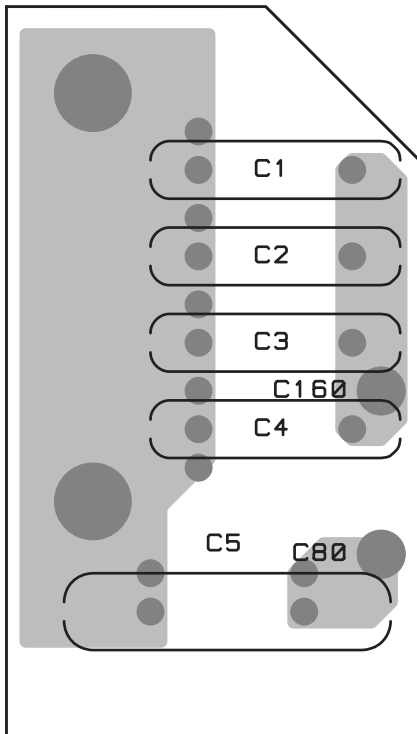

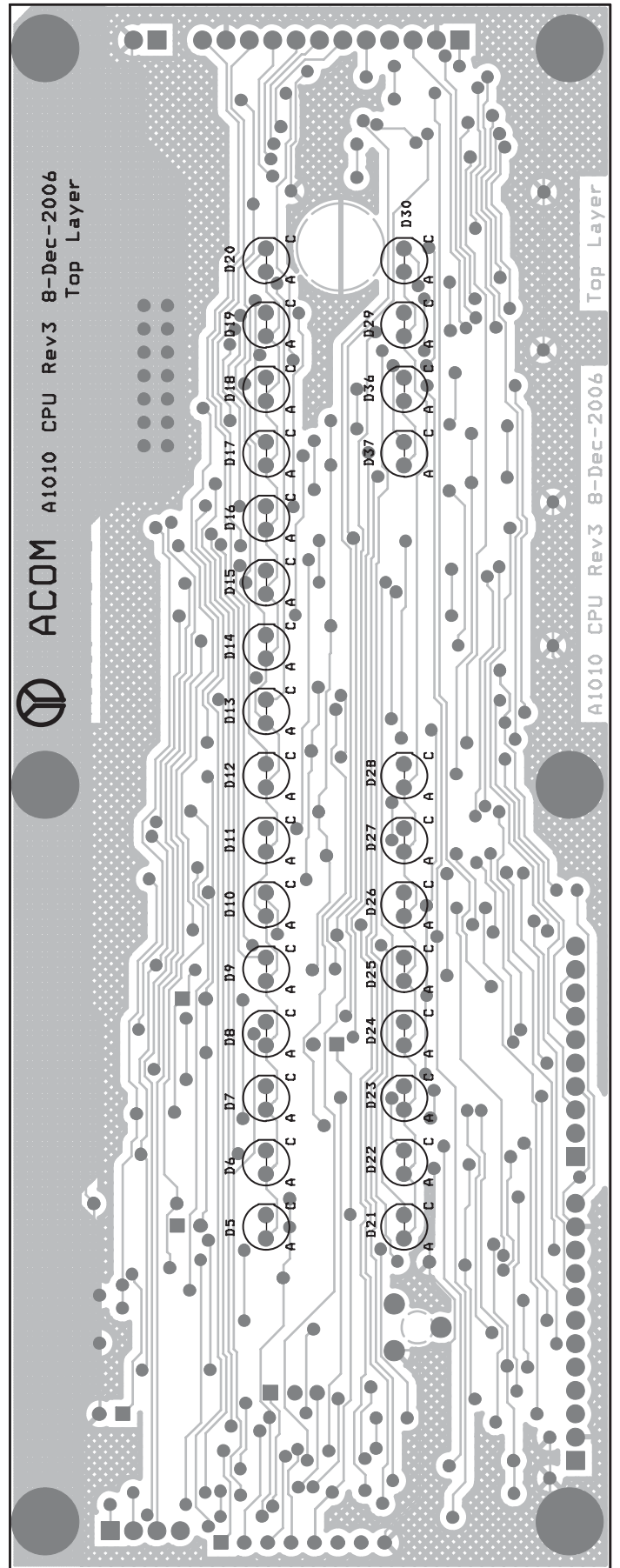

**CENTRAL PROCESSOR UNIT**  
Component side

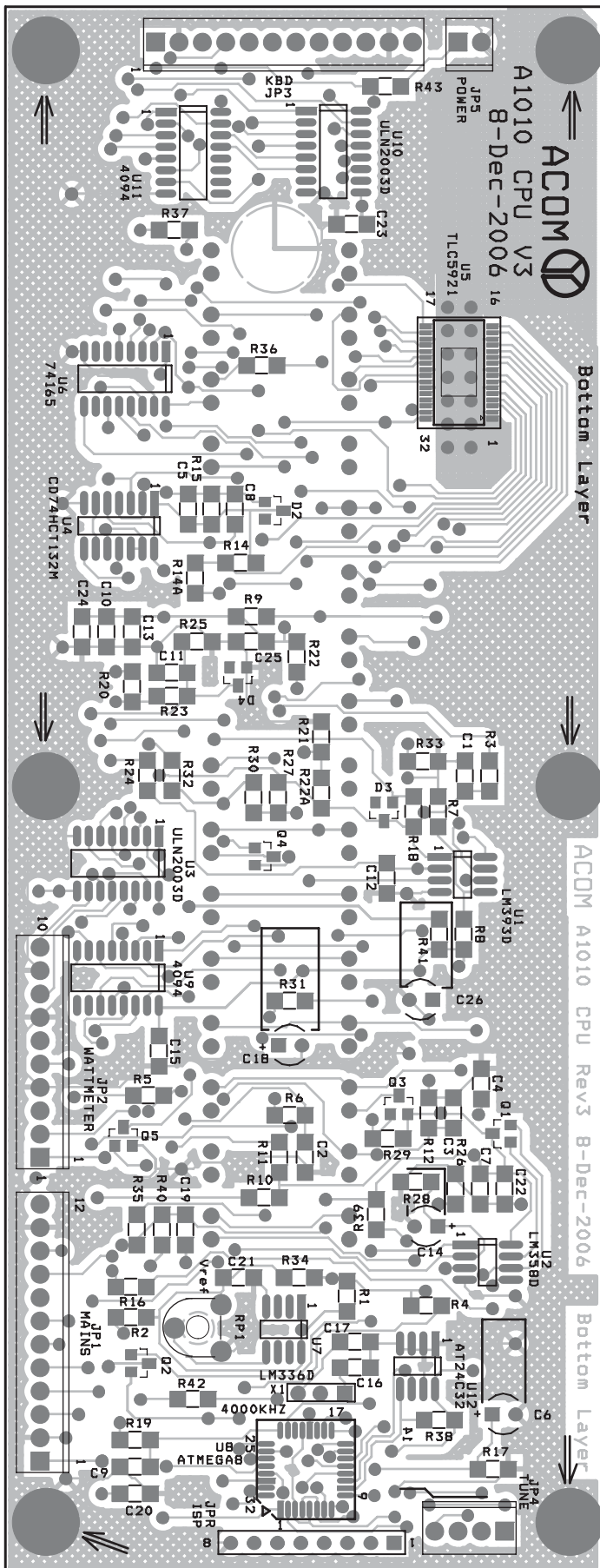

CENTRAL PROCESSOR UNIT  
Solder side

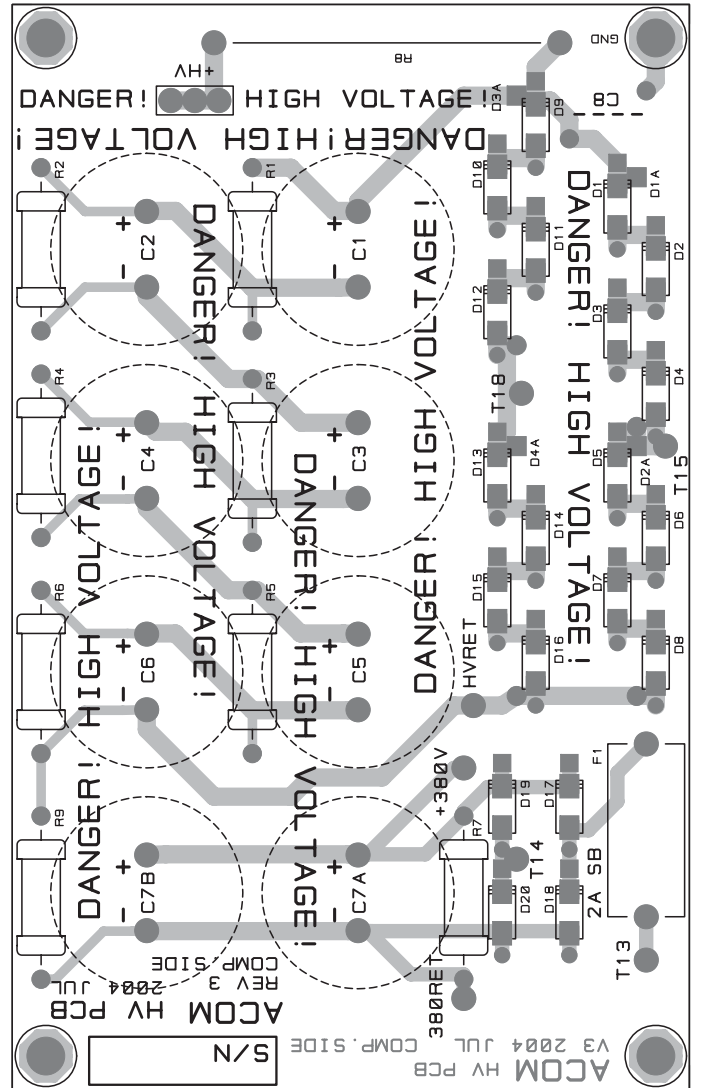

**HV POWER SUPPLY**  
**Component side**

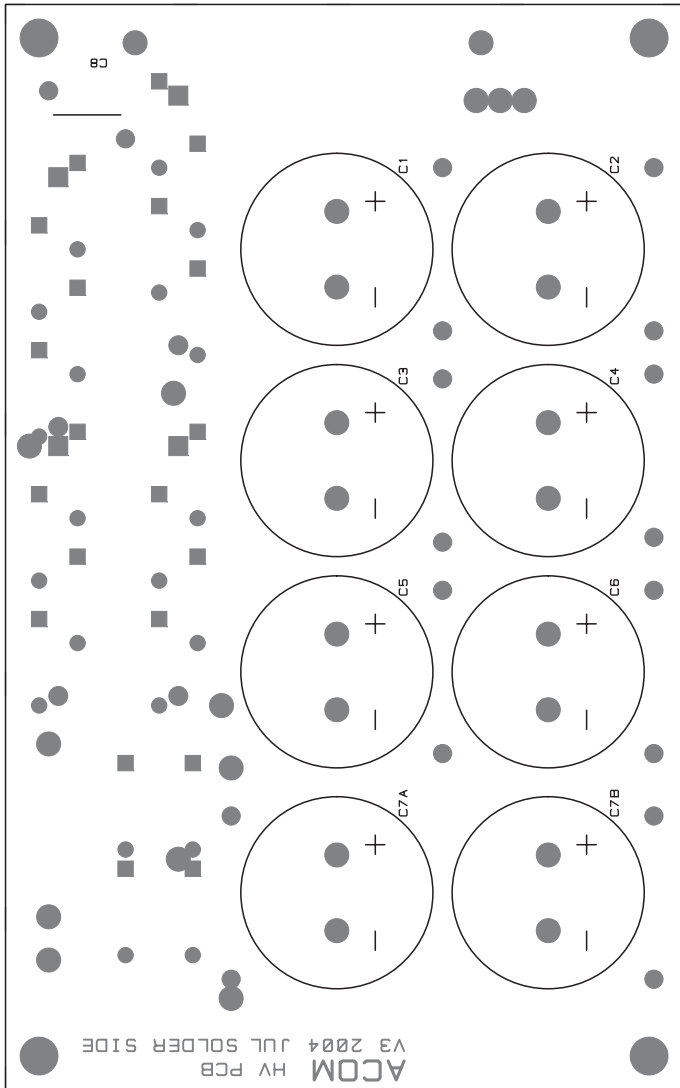

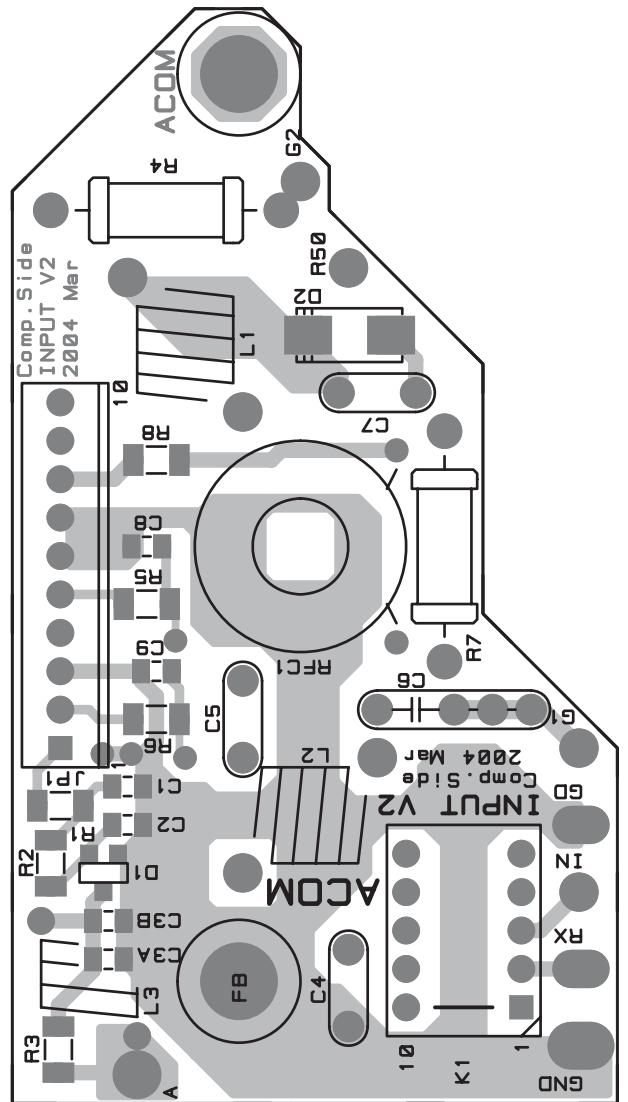

**INPUT BOARD**  
Component side



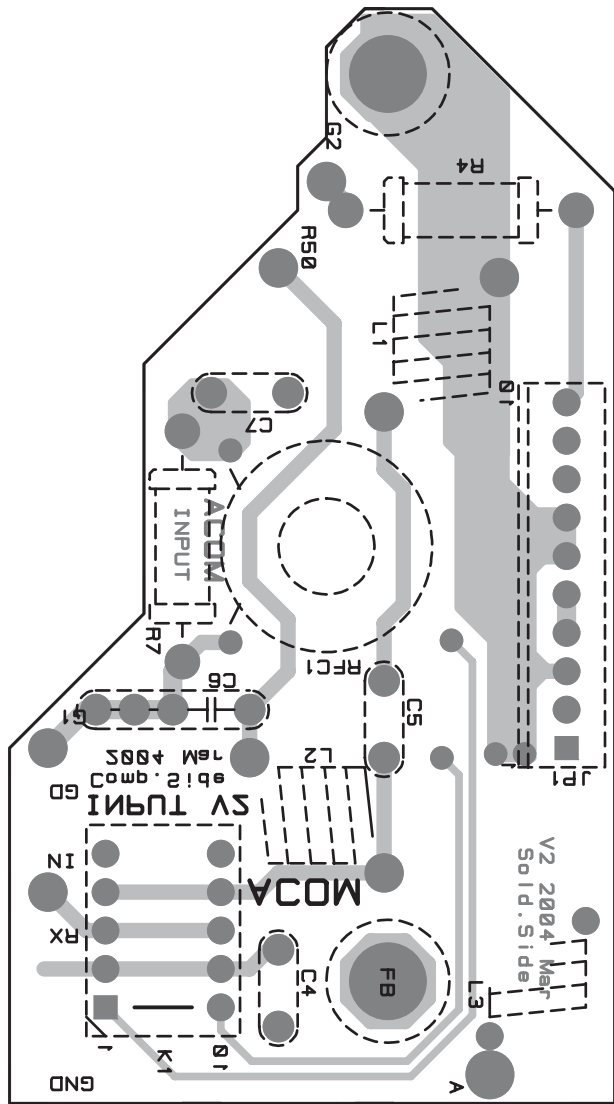

**INPUT BOARD**  
**Solder side**

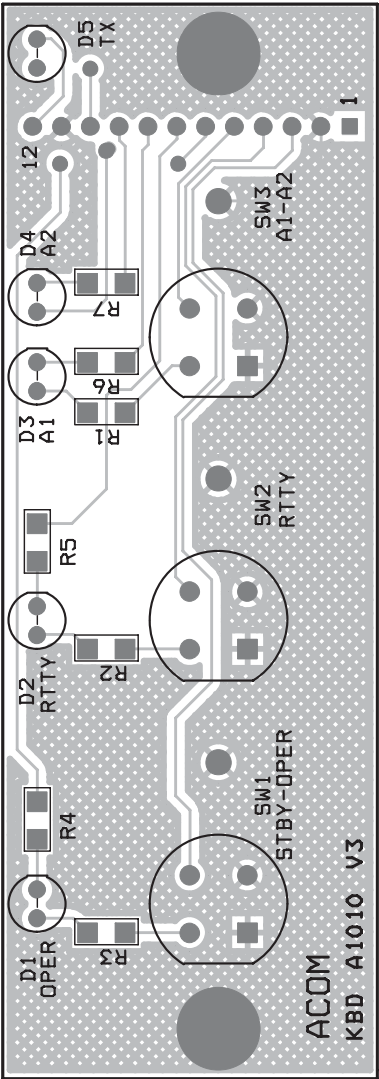

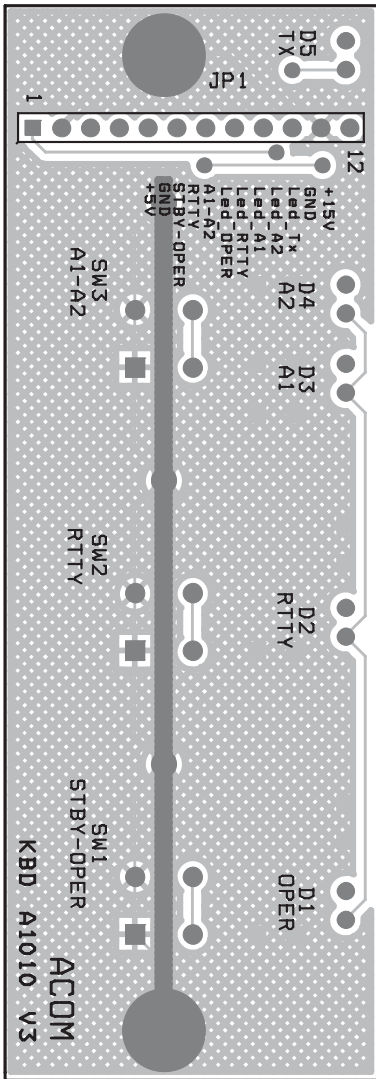

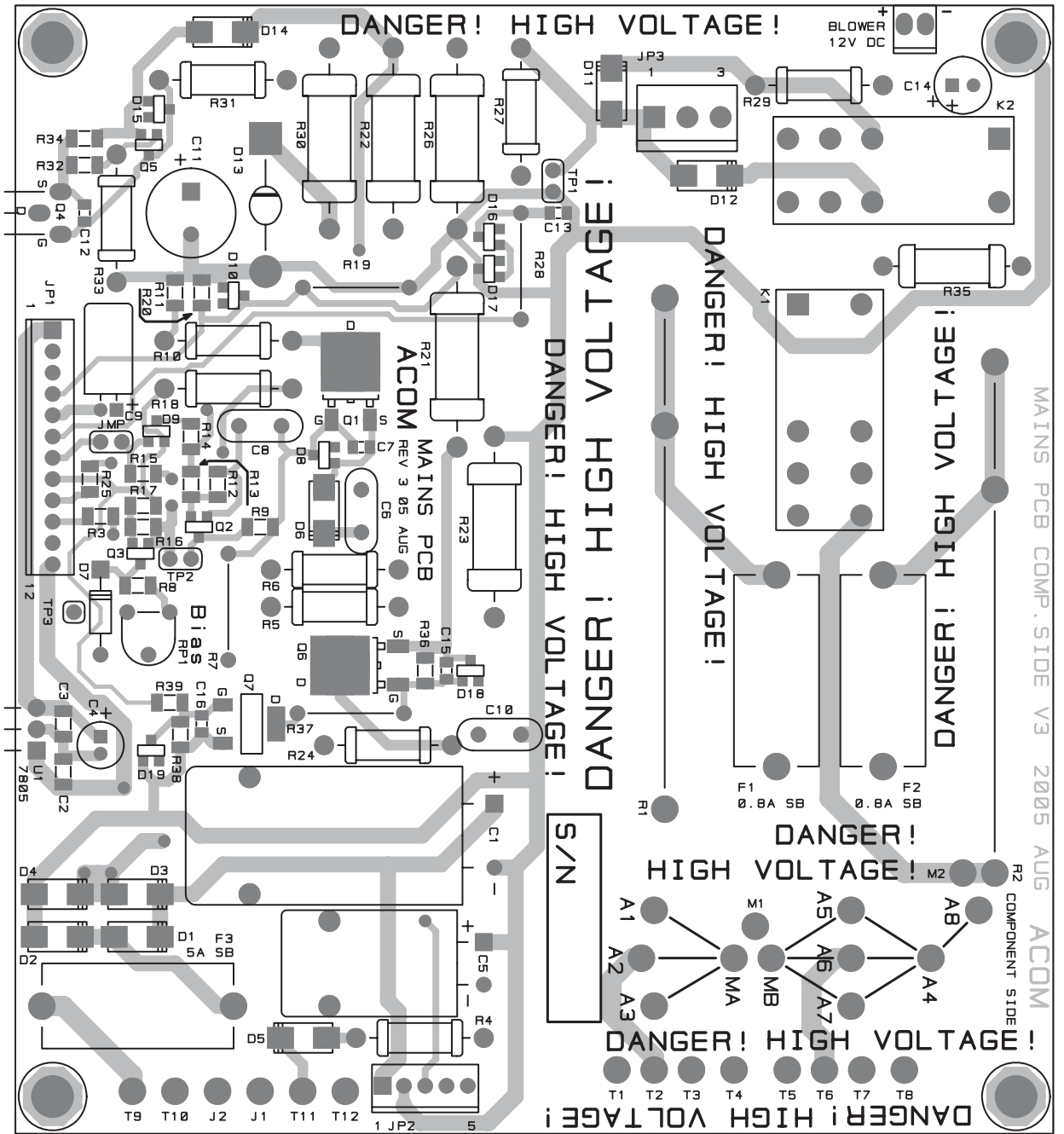

**MAINS&LV POWER SUPPLY**  
**Component side**

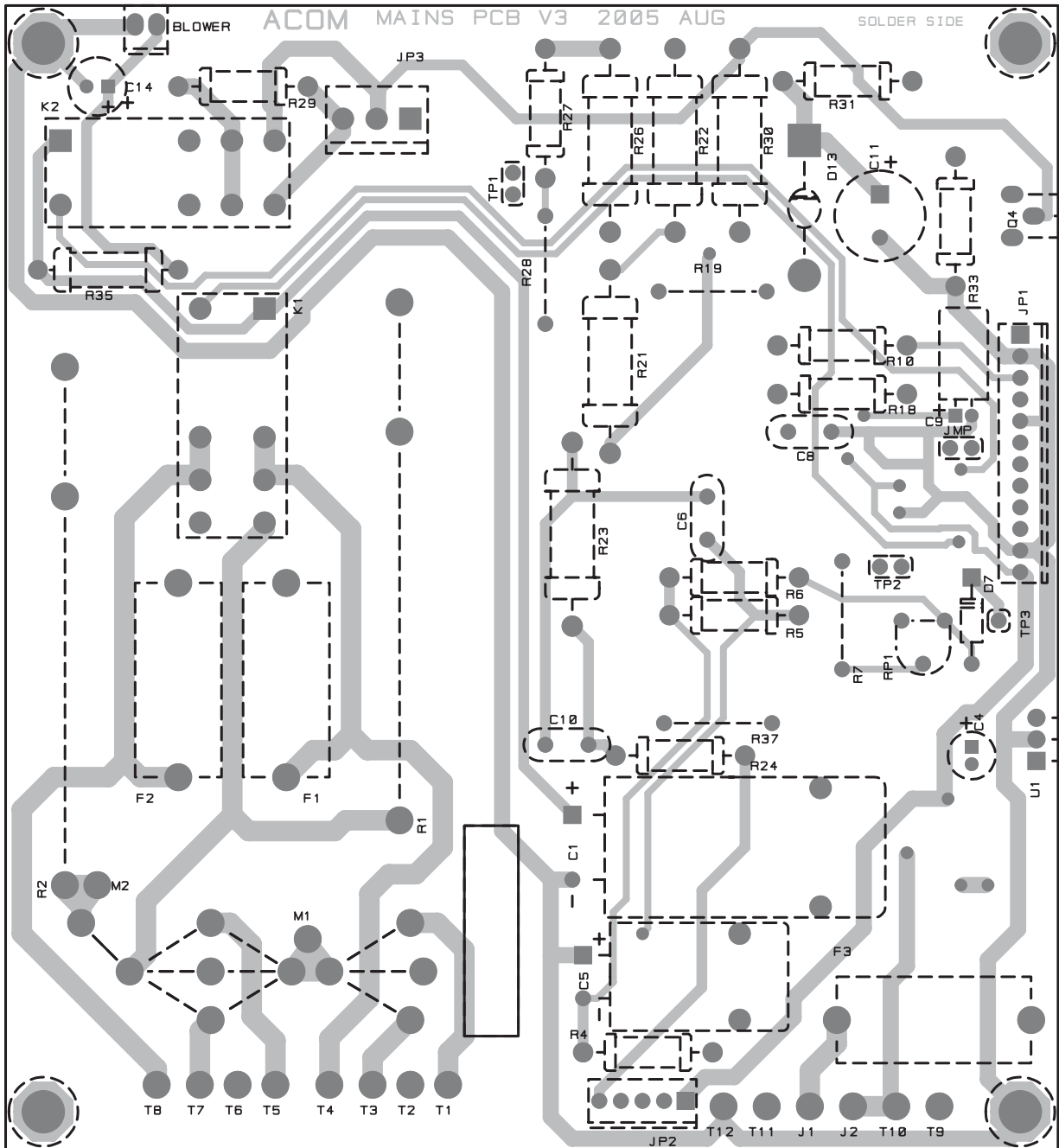

**MAINS&LV POWER SUPPLY**  
**Solder side**

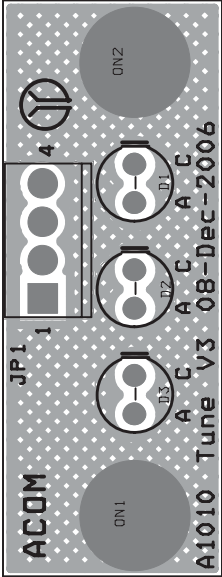

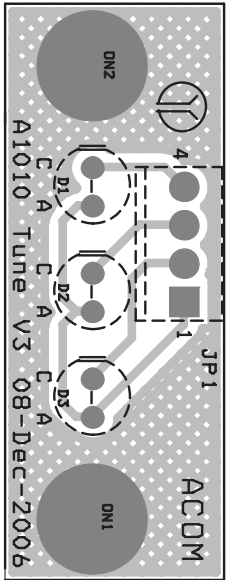

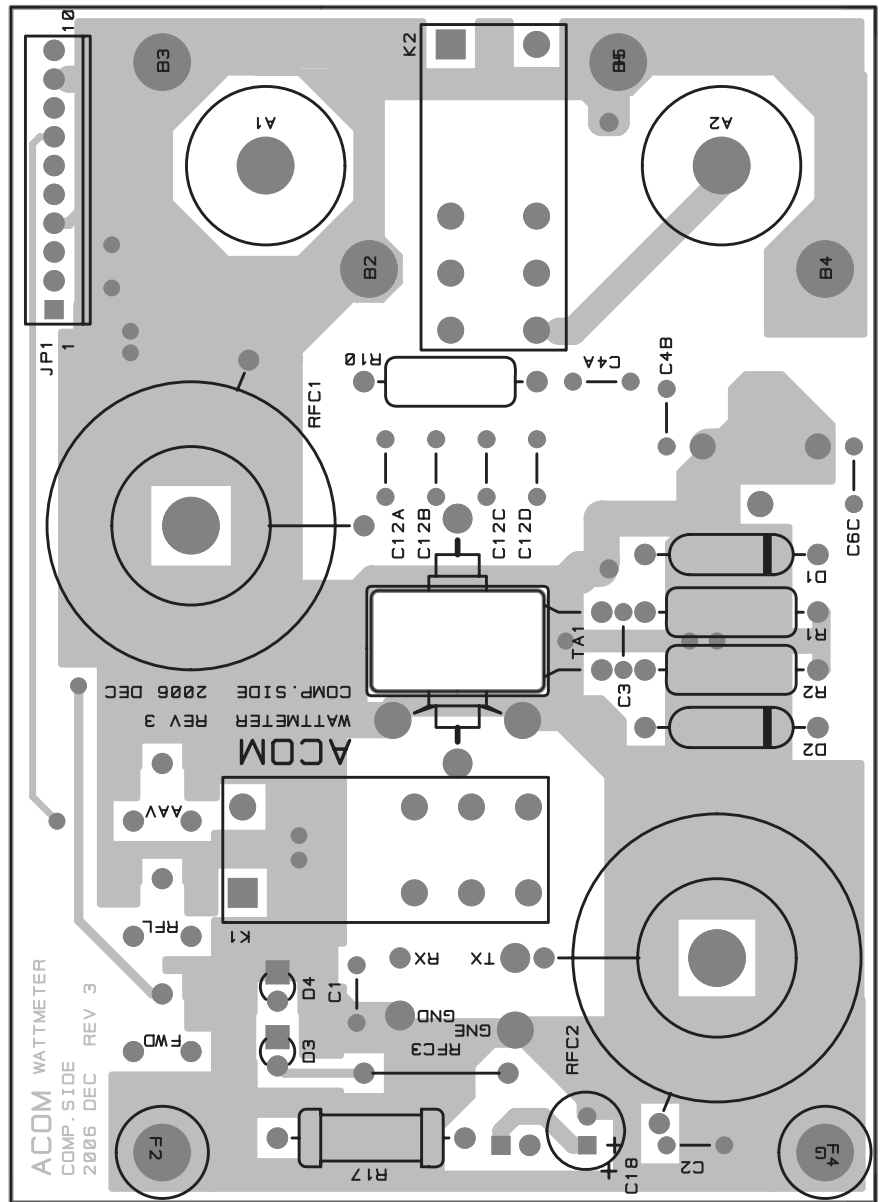

**WATTMETER**  
Component side



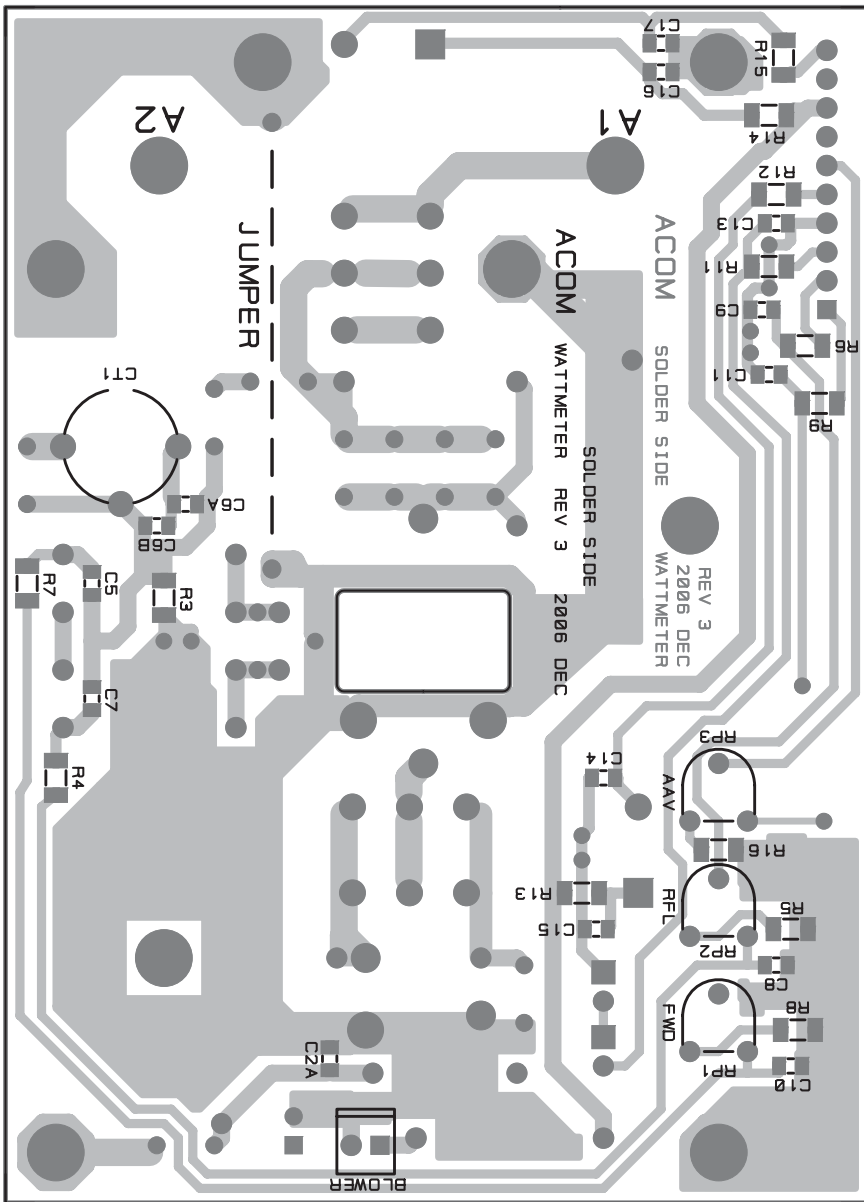

**WATTMETER**  
Solder side