

Bolt Down Mounting Method for High Power RF Transistors and RFICs in Over-Molded Plastic Packages

By: Mahesh Shah, Richard Wetz, Lindsey Tiller, Leonard Pelletier, Eddie Mares and Jin-wook Jang

INTRODUCTION

The purpose of this application note is to provide Freescale Semiconductor customers with a guide for mounting high power RF transistors and integrated circuits in Over-Molded Plastic (OMP) packages by bolting down instead of soldering down. This guide is intended to aid customers in developing an assembly process suitable for their design as well as their manufacturing operation. Each Power Amplifier (PA) design has its own unique characteristics. Similarly, each manufacturing operation also has its own process capabilities and variations. Therefore, each design and assembly may require some fine-tuning. The intent of this application note is to provide as much information as we can to help our customers derive the best possible process that is both suitable for their design and compatible with their manufacturing operation.

Based on the guidelines demonstrated here, customers should be able to develop a manufacturable assembly process that can do the following:

- Provide a good thermal ground to conduct the dissipated heat efficiently from the high power RF device to the system sink
- Provide a good electrical ground to provide a stable RF performance over the life of the power transistor
- Obtain a high quality solder joint between the device leads and the solder pads on the printed circuit board (PCB) to ensure good field reliability
- Maintain the package integrity during the assembly and in the field

In order to develop proper assembly processes, it is important to understand the evolution of RF power transistors in OMP packages.

BACKGROUND

Semiconductor devices were first manufactured using metal-ceramic headers in hermetic, metal can type packages. Over-molded plastic (OMP) packages manufactured using a transfer molding technique became available as the integrity of the die level passivation and the purity of the mold compounds improved. Freescale provided low frequency power devices using exposed pad, OMP packages for over 35 years. Many of these devices have been

qualified to the highest quality standards in the commercial semiconductor industry; namely, automotive quality standards such as the AEC specification. In the mid-1990s, Freescale pioneered the introduction of high power OMP packaging technology into high frequency, high power applications. Later, we advanced this technology from discrete devices to multi-lead integrated circuit (IC) devices. Today, we offer RF power transistors and IC devices in OMP packages that are capable of an RF output of over 100 Watts and a frequency range up to 2 GHz. We continue to offer metal-ceramic Air Cavity (AC) packages as well.

Until the early 1990s, the industry trend was to bolt down RF power devices. In the mid-1990s, high power RF devices that could be soldered instead of bolted down became available. Soldering devices offers many advantages:

- The soldered interface provides better thermal performance as well as electrical grounding. This means that the high power devices have a lower junction temperature as well as better RF performance, when mounted in a PA with a soldered interface.
- The reduction in junction temperature for all semiconductor devices results in an increase in a device's Mean-Time-To-Failure (MTTF). For Si-based devices, each 10°C to 20°C reduction in junction temperature typically results in a doubling of the MTTF.

Although soldering offers many advantages, some customers still prefer bolt down RF power transistors so Freescale continues to offer both options.

As demand for OMP packages increased dramatically, extensive effort has been made to automate the assembly and test operations from piece part manufacturers to semiconductor assembly factories. The added benefit of automation in manufacturing RF power devices is that much tighter tolerances are possible in OMP packages than were previously feasible in AC packages. Freescale offers LDMOS RF power transistors as well as RFIC devices that can be assembled into a PA using the following:

- Bolt down assembly
- Solder reflow assembly
- Surface mount technologies

The most commonly used OMP packages for RF power devices are the TO-272 (Cases 1264A and 1337) and the TO-272-WB (Cases 1329 and 1484). Figure 1 shows typical devices from this group. These devices are available in a variety of lead sizes, lead pitch and number of leads (2 to 16 leads).

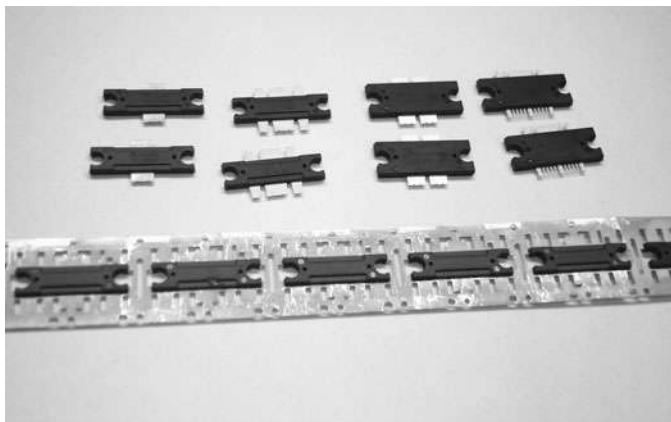

Figure 1. Typical RF Power Devices in Over-Molded Plastic Packages Suitable for Bolt Down Assembly Operation

PACKAGE CONSTRUCTION

As mentioned earlier, RF power transistors are manufactured in both AC and OMP packages. Figure 2 shows a typical cross-section of an OMP package.

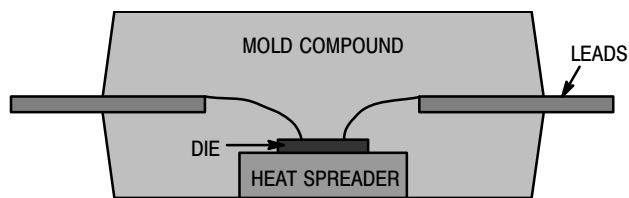

Figure 2. Plastic Package Construction for Power Devices

Both AC and OMP packages are RoHS compliant. Both are nonhermetic packages. The key differences between the two package technologies are as follows.

- In AC packages, the Si die is typically attached to a CuW or other composite metal heat sink using a AuSi-based eutectic die attach.
- In OMP packages, the Si die is typically attached to a Cu alloy heat sink using high Pb-based soft solder.
- In AC packages, the die and wire bonds are surrounded by a low die-electric material such as air (hence, the name).
- In OMP packages, the die and wire bonds are in direct contact with a higher die-electric mold compound.

The case outline dimensions show that the tolerances for key features such as seating plane height (SPH) and lead co-planarity are significantly tighter for OMP packages than

for AC packages. The tighter tolerances can also permit automation of the next level assembly, such as the assembly of the PA board. It is also expected that tighter tolerances will reduce the variability in RF performance. Inherently, the bolt down of power transistors and solder down of the leads requires a more manual assembly process than do other mounting methods, such as solder reflow of RF power devices in a pallet or coin and surface mount of RF power devices.

PCB LAYOUT GUIDELINES AND SOLDER PAD DIMENSIONS

For the bolted down RF power device, the leads must be soldered on the top surface of the printed circuit board (PCB) while the flange or the heat spreader in the package is bolted to the mechanics or PA housing. This requires a slot, or opening, in the PCB through which the RF power device protrudes. If the thickness of the PCB is smaller than the seating plane height of the RF power device, it must sit in a cavity machined out in the PA housing. If the PCB thickness is larger than the seating plane height of the RF power device, it must sit on a pedestal in the PA housing. The case outline drawing shows the length and width dimensions at the bottom surface of the leads. The minimum dimensions (nominal minus milling or punching tolerance for the PCB) for the slot should be at least 0.001" (0.025 mm) and preferably 0.002" (0.05 mm) larger than the maximum dimension of the package.

For example, Case 1329 shows dimension D as the length of the package and dimension E2 as the width of the package underside. The maximum value of D is listed as 0.932" (23.67 mm); therefore, the length of the slot should be a minimum of 0.934" (23.72 mm) and preferably 0.935" (23.75 mm). Similarly, the maximum value of dimension E2 is 0.350" (8.89 mm), and the minimum slot width should be 0.351" (8.92 mm) and preferable 0.352" (8.94 mm). Normally, there is a corner radius in the slot based on the mill or router diameter. This radius value should also be considered when defining the size of the slot. The length dimension of the slot can be enlarged so that the corner radius will clear the body of the RF device. In general, for RF performance and for consistency, the slot width should not be much larger than the package body.

On the top surface of the PCB, there are solder pad areas for soldering the leads to the traces on the PCB. It is good manufacturing practice to pull back these metal traces from the edge of the slot. PCB manufacturers should provide a design rule on how far these metal traces should be pulled back from the edge of the slot. In the absence of a PCB design rule, Freescale recommends that the metal in the solder pad area should be at least 0.010" or 0.25 mm from the edge of the slot. The outside edge of the solder pad should be longer than the outside tip of the leads by a minimum of 0.010" (0.25 mm). Similarly on the width direction, the design rules from the PCB supplier and the assembly process should be followed in terms of how close the two adjacent pads of metal should be to define the pad width. In the absence of a PCB design rule, we recommend that the metal in the solder pad area should be at least 0.010" (0.25 mm) wider than the lead width. For multi-lead IC devices (Case 1329), however, this may not be feasible due to the close proximity of some leads.

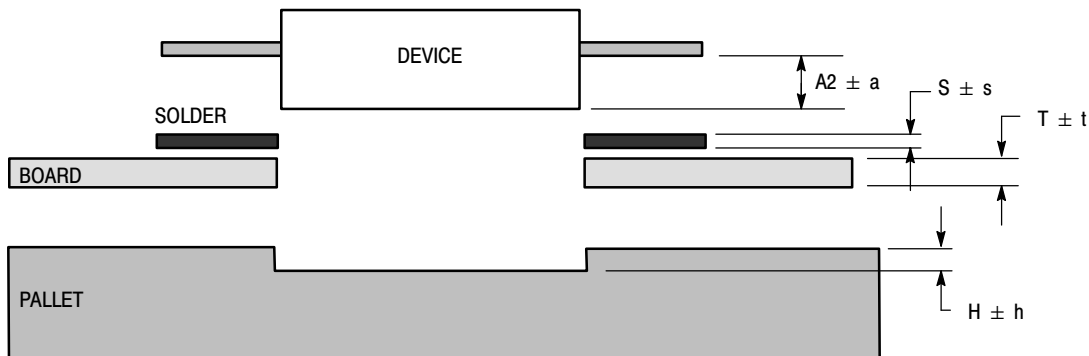

Figure 3. Cavity Depth Dimension

In addition to the metal sizes, there is also the opening in the solder mask. The industry has two common practices: using a solder mask defined pad or using a copper defined pad. In the solder mask defined pad method, the solder mask overlaps the underlying metal pad which is slightly larger than the solder mask opening. In the copper defined pad method, the solder mask opening is slightly larger than the exposed metal pad. The type of solder mask opening used is entirely based on the PCB supplier's preference and the preference of the PA board assembly operation. In either case, we recommend that the design rules from the PCB suppliers should be followed for the solder mask opening. Typically, the difference between a solder mask opening and a copper pad is 0.003" (0.076 mm) per side.

The recommended solder pad dimensions as well as the slot dimensions for various case outlines of bolt down plastic parts are shown in Appendix A. The dimensions shown there are to be used as a guide and should be validated with the design rules from the PCB supplier as well as the assembly process. In case of conflict, the PCB supplier design rules should supersede the recommendations in Appendix A.

CAVITY HEIGHT DIMENSIONS AND TOLERANCES

Another key feature for good device mounting is determining the cavity depth or pedestal height. In the bolt down assembly method for RF power devices, the leads are soldered to the top side of the PCB with the device protruding in a slot through the PCB. The heat spreader or source contact of the RF device is mounted on the machined or die cast housing. Considering the variety of PCB materials and different PA designs, it is very likely that the PCB thickness and the seating plane height of the device will not be the same. If the seating plane height of the RF power device is larger than the PCB thickness, the PA housing must have a cavity in which the RF power device will sit. If the seating plane height of the RF power device is smaller than the PCB thickness, the PA housing must have a pedestal on which the RF power device will sit. Therefore, the cavity depth or pedestal height is very important for good mounting.

In defining the cavity depth or the pedestal height, two things must be considered:

- Most importantly, the RF power device should have a good contact with the housing at the bottom of the device.

- The resulting forces on the solder joint should be compressive rather than tensile. The solder joint stresses are even more critical when the device is soldered to the PCB before bolting.

If the RF power device heat spreader or source contact is not seated in a PA housing with good clamping force, the device will have a poor electrical and thermal ground, which will adversely affect the device performance. Freescale does not recommend bending the leads to accommodate such dimensional differences. If the application requires that the leads must be bent, we suggest contacting the experts within Freescale for advice on the proper precautions that must be taken during the lead bending operation.

Figure 3 shows a typical cross-section of all the major components in the installation of an RF power device. There are four key elements in the vertical dimension:

- Device seating plane height ($A2 \pm a$)
- Cavity depth ($H \pm h$)
- PCB thickness ($T \pm t$)
- Solder paste thickness ($S \pm s$)

In addition to the nominal value for each of these dimensions, there is a tolerance band in which each of these dimensions will vary. One way to look at the extreme values is as a worst-case analysis. If the cavity depth dimension is calculated based on the worst-case analysis, that dimension is optimum only when all extreme dimensions occur simultaneously, which is extremely rare.

A more realistic approach is to make an assumption that all vendors specify the tolerance band to avoid significant yield loss. Thus, it is safe to assume that the mean value of the dimensional distribution is at the nominal and the standard deviation on each dimension is such that the process has a Process Capability Index (Cpk) of at least 1.0 and preferably 1.5. If we assume that Cpk for the RF power device is 1.0 and the seating plane height dimension is $0.041" \pm 0.001"$ (1.04 ± 0.025 mm), the mean value for the seating plane height distribution is at 0.041" (1.04 mm) and the standard deviation is 0.0003" (0.008 mm). After the standard deviation for each dimension in the chain is determined, it can be combined using the square root of sum of squares method to determine the variation in the installation. When that is determined, the required cavity depth or pedestal height can be calculated.



Figure 4. Simulated Bolting Down on Non-Flat Surface

Let us assume that an RF power device with a seating plane height dimension of $0.041'' \pm 0.001''$ is soldered down to a PCB with a thickness of $0.032'' \pm 0.003''$ with a solder joint of $0.002'' \pm 0.001''$. This assembly is then mounted in the housing with a cavity of depth H. Based on the method described above, the device can protrude below the bottom surface of the PCB by $0.007'' \pm 0.001''$ (between 6 and 8 mils). If the machining tolerance for the cavity depth is $\pm 0.001''$, the cavity depth should be 0.006", 0.007" or 0.008" nominal. To obtain a compromise between possible tensile load on the solder joint and the downward force on the lead, a cavity depth of $0.007'' \pm 0.001''$ should be selected.

If the devices were to be bolted first and then the leads soldered, a similar analysis would suggest that the cavity depth should be $0.006'' \pm 0.001''$. This would result in a solder joint between 0.001" and 0.003".

The example shown above is for the condition where the device seating plane height is higher than the PCB thickness. The same methodology can be used to determine the pedestal height if the PCB thickness is higher than the seating plane height of the device. The method shown here should be used as a guide to determine exact dimensions that can yield a workable compromise for all possible conditions and still yield acceptable reliability for the system based on the capability of assembly processes.

MOUNTING SURFACE REQUIREMENTS

In RF power devices, the heat is conducted from the die to the backside of the power device heat spreader and from there to the PA housing. Thus, the interface between the power device and the housing plays a very important role in both thermal and electrical grounding. For bolt down assemblies, the PA housing is typically machined or die cast using aluminum alloy. Both the roughness and the flatness of the housing mating surface are important parameters for good RF performance as well as device reliability.

For surface flatness, Freescale uses the criteria of 0.4 mils/in. (0.4 micron/mm) as a design limit. All of our RF power device packages are designed to survive repeated bolting down on a surface with a minimum of that amount of flatness. RF power devices in OMP packages were tested by bolting



Figure 5. Mounting Hardware: Socket Head Cap Screw, Split and Flat Washers

them down on a ridge to simulate excessive non-flatness of the mating surface (see Figure 4). The devices were tested on a ridge of 0.75 mil (0.019 mm). At a 0.81" (20.57 mm) bolt center, this is equivalent to 0.93 mils/in. (0.93 micron/mm). The devices were checked for RF performance and mechanical integrity. No shift in RF performance between before and after bolting the parts on a 0.75 mil (0.019 mm) ridge was detected. Also, none of the samples indicated mechanical failure of the package, such as cracking. The devices were tested to more than double the specification limit recommended here with no failures.

In addition to surface flatness, surface roughness is another important parameter. Roughness is a measure of finer irregularities in the surface texture. It is typically specified in an arithmetic average of all deviations of the surface profile from the nominal profile. Sometimes, it is also referred to as roughness height instead of surface roughness. For surface roughness, Freescale recommends the criteria of average roughness (Ra) of 32 micron-inches (0.8 microns). Both of these values are easily attainable by common machining operations, such as milling, without resorting to more expensive processes such as surface grinding or polishing. Typical cast surfaces will probably not meet this criteria; therefore, we recommend that the area of casting where the power devices are going to be situated in the housing should be finished with light machining to improve both flatness and roughness. We do not recommend mounting the power devices directly on the nonmachined surface of the casting.

SELECTION OF MOUNTING HARDWARE

Selection of mounting hardware is another important factor for a good, reliable installation of high power devices. In applications in which the devices are exposed to a significant amount of thermal expansion or vibration, it is very possible that the screw will loosen over temperature cycling. For a bolted joint, it is important that the joint remain in net compressive force all the time. To ensure this, a flat and a lock or split washer should be used with a bolt (see Figure 5). A flat washer tends to spread the bolt load over a larger area, and the split washer provides the necessary expansion or compression to accommodate thermal compression or

expansion in the bolted joint. Both AC and OMP RF power packages are designed to accommodate either #4-40 or M3 screws.

The maximum body diameter for a #4-40 screw is 0.112". The standard flat washer dimension for a #4-40 screw has an inside diameter of 0.125" and an outside diameter of 0.25". The standard spring or split washer for a #4-40 screw has an inside diameter of 0.12" and an outside diameter of 0.209". The standard tightening torque for a #4-40 steel screw is 5 in. - lbs.

In metric sizes, the maximum body diameter for an M3 screw is 3.0 mm. The standard flat washer dimension for an M3 screw has an inside diameter of 3.2 mm and an outside diameter of 7.0 mm. The standard spring or split washer for an M3 screw has an inside diameter of 3.4 mm and an outside diameter of 6.2 mm. The standard tightening torque for an M3 steel screw is 0.6 N-m.

In some countries, M2.5 or M2.6 bolts, smaller than M3 bolts, are used. RF power devices can accommodate these two screw sizes, but they have a slightly lower clamping force than do M3 screws. Freescale performs all tests using #4-40 screws, which are almost identical to M3 screws. In many applications, M2.5 or M2.6 screws may be perfectly acceptable, but if customers plan to use these, we recommend that they validate that these will not affect the performance or reliability of the RF power device.

Two key differences between OMP and AC packages should be pointed out. First, plastic packages are 0.106" (2.69 mm) in thickness, whereas the metal-ceramic or AC packages can have flanges that are up to 0.066" (1.68 mm) thick. For AC packages, a 0.25" (6 mm) screw length is adequate. For plastic packages, we recommend a screw

length of 0.375" (10 mm). Hex head cap screws are preferred because it is possible to torque the device fully without concern about torque wrench slippage. A calibrated torque wrench with a good grip is very important for the installation of high power devices.

Second, in AC packages, the bolt head is in direct contact with the metal flanges. Therefore, it does not matter if the washer dimensions are smaller, similar to some captive washers used in the industry. In plastic packages, the bolt head is in direct contact with the plastic mold compound; therefore, it is important that the bolt load is spread over a larger area. The use of significantly smaller size washers than the dimensions mentioned here can result in chipping of the plastic corners. We do not recommend using washers that are smaller than 0.2" (5.0 mm) in diameter.

A good bolt tightening practice is a three-step process:

1. Tighten both screws on the individual device to what is commonly called "finger tightening."
2. With the torque wrench, partially tighten each screw.
3. After all of the screws are partially tightened, tighten each screw to a full-rated torque.

When the screws are tightened in this fashion, there is less likelihood of creating excessive bending in the devices.

Two #4-40 screws when torqued to 5 in. - lbs. of tightening torque generate as much as 450 lbs of clamping force on the plastic body of an RF power device. As shown in Figure 6, the plastic packages are designed to withstand this amount of force with no problem. These devices have been tested to withstand up to 750 lbs (340 kgf) of force distributed over the two bolt hole regions with no adverse impact on mechanical integrity or RF performance of the device.

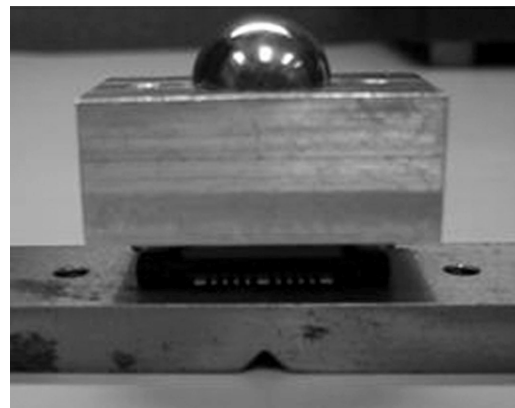
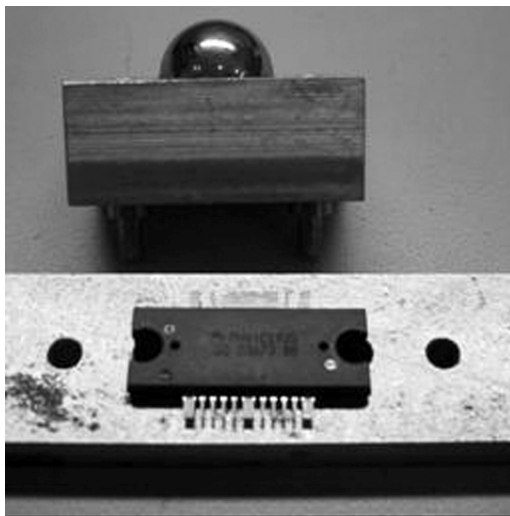

Figure 6. Simulated Bolt Down Load Testing

SELECTION OF THE INTERFACE PAD

Besides the dimension of the cavity and the mounting hardware, another important factor in achieving good performance from these devices is the interface between the bottom of the RF device and the PA housing. The interface has two functions:

- It provides a thermal ground to conduct the heat away from the heat spreader of the device to the PA housing and from there to the BTS ambient air via the finned heat sink of the PA module.
- It provides an electrical ground to the source contact of the RF device. Proper electrical grounding is very important for consistent and stable RF performance of the device.

In Freescale's internal testing, we predominantly use a thermal grease interface to bolt down the part in the test fixture. The grease thickness used is approximately 1 mil (25 micron). Some customers find that in their systems, the PA performance is much more stable when a more thermally and electrically conductive pad is used under the RF devices. Some of the common conductive pad materials are metals such as indium foil, copper foil, solder foil, etc., and

graphite-based materials such as TGON® and PGS®. We recommend the use of a conductive pad with the same footprint as the RF device. We do not recommend using partial footprint pads. Figure 7 shows some of the pads for the RF power devices in Cases 1329 and 1484.

Indium has been used as an interface material in many applications, particularly in military and space-based modules. Indium foil is probably the most expensive in the group. Because indium is a material that is not commonly used in base stations, we recommend that customers evaluate if the indium pad is going to interact with their PA module material or its coating over the life of the PA module. Solder foil consists of the material that is commonly in contact with the RF device as well as the PA housing material. Thus, it does not add a new metal element in the system that may be susceptible to galvanic corrosion. Sometimes, the solder foil may have a flux coating on the foil. If the flux is not desired, it can be cleaned off for use in this type of application. Copper foil is probably the least expensive and is also made from the material that is commonly used in contact with the RF devices as well as the PA housing. Again, it does not introduce another new metal element that may cause additional galvanic corrosion concerns.

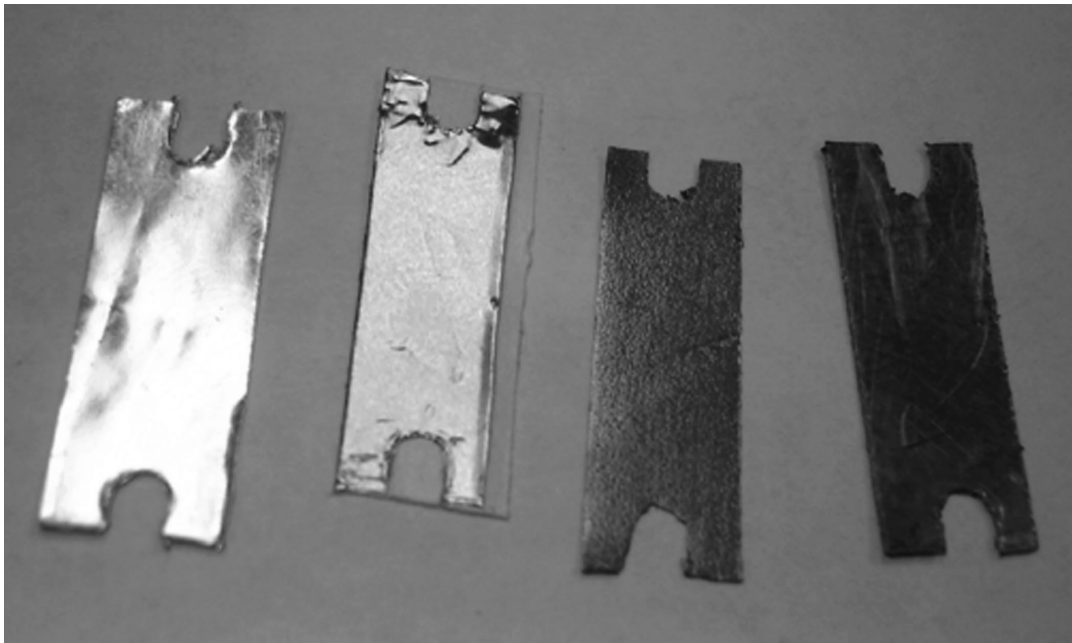

Figure 7. Various Interface Pads.
Left to right: Indium Foil, Copper Foil, PGS® Pad and TGON® Pad

Table 1. Comparison of Different Interface Materials

Interface Material	V _{DD} V	I _D A	P _D W	Thermal Resistance °C/W	Voltage Drop through Interface mV
Thermal Grease	26.0	3.05	79.37	0.43	1.72
TGON-805	26.0	2.97	77.23	0.26	17.97
PGS	26.0	3.02	78.47	0.20	10.56
Indium Foil	26.0	3.03	78.88	0.25	2.05
Copper Foil	26.0	3.07	79.72	0.26	1.98

The advantage of TGON and PGS materials is that both are polymers and are made from graphite material. PGS is a crystalline graphite sheet, whereas TGON is an amorphous graphite material. PGS is available in 4 mil (100 micron) thickness, whereas TGON material is available in 5 mil (125 micron) thickness (TGON-805). Both materials can be stamped to the same footprint as the RF power device. Freescale tested five devices in OMP packages under DC conditions to measure the temperature rise between the top of the package and the case temperature. Table 1 lists the average thermal resistance between the top of the plastic and bottom of the case for these five devices in different interface materials as well as the voltage drop through the interface.

Considering the cost of the material, the potential for corrosive interaction over long-term usage and the thermal and electrical performance, we recommend the use of TGON-805 material as the interface pad for the OMP devices as our first choice. If customers have a PA design that requires an electrically more conductive pad, they should consider the other metallic materials described above. We recommend that when different metallic materials are being considered for the interface pads, their susceptibility to interact with pure-Sn or Sn-Pb plating on the backside of the OMP devices as well as the material and plating of the PA housing should be considered in the selection.

HANDLING AND STORAGE OF PLASTIC DEVICES

The semiconductor industry has developed an industry-wide standard—JEDEC J-STD-020—for moisture and reflow sensitivity classification for nonhermetic surface mount devices. In many cases, bolt down packages may not go through a solder reflow operation because many customers do not want to bolt the parts after soldering them down. In some cases, because of high-speed automation considerations, customers may choose to reflow the device and then bolt the device and the PCB together in the PA housing.

For this reason, all of Freescale’s OMP packages have been rated for their moisture and reflow sensitivity level (MSL) based on JEDEC J-STD-20. Most of the devices are qualified to an MSL rating of 3 at 260°C maximum package peak temperature. Because of an MSL rating below 1, these

devices are normally shipped in a vacuum pack. The handling, storage and use of such devices on the customer’s assembly floor should strictly adhere to JEDEC J-STD-33. This standard defines the shelf life of the devices after they are removed from their vacuum pack. It also defines the conditions for drying such devices to reset the floor life after moisture exposure. It should be noted that the drying is typically specified at either 40°C, 90°C or 125°C. The baking time for an MSL 3 rated part at 40°C is in months, which is not very practical. In addition, the tape and reel material in which RF power devices are shipped cannot withstand temperatures higher than 70°C. If such devices must be dried to reset the floor life, they should be removed from the tape and reel and dried in a tray that can handle the drying temperature of 125°C.

SOLDERING PROCESS FLOW

OMP RF power devices can be assembled in the PA assembly in two possible methods. In one method, particularly for the discrete devices in Cases 1337 and 1484, the lead spacing is adequate for hand soldering. For the devices in cases such as Case 1329, the lead spacing may be too close for hand-soldering the devices by some assembly operations. In that event, one possible way to assemble these devices in a PA assembly is to reflow and then bolt down. One key condition for the assembly process is to have a correct cavity depth or pedestal height so that the solder joint and leads do not have excessive stress imposed on them by mounting. A typical solder process flow for both methods is provided here as a guide.

Soldering after Bolt Down

The process flow for the soldering after bolt down is shown in Figure 8. In this assembly process, the PCB is first reflowed with all the components using a conventional process, such as solder screen printing, pick and place components and solder reflow. The PCB can then be cleaned to remove flux if desired. The completed PCB is then bolted down in the PA housing. The interface pads are put in place and aligned with the bolt holes. The RF power device is then inserted in the PCB slot and aligned with the solder pads on the PCB and the bolt holes. The RF device is bolted down using proper tightening torque.

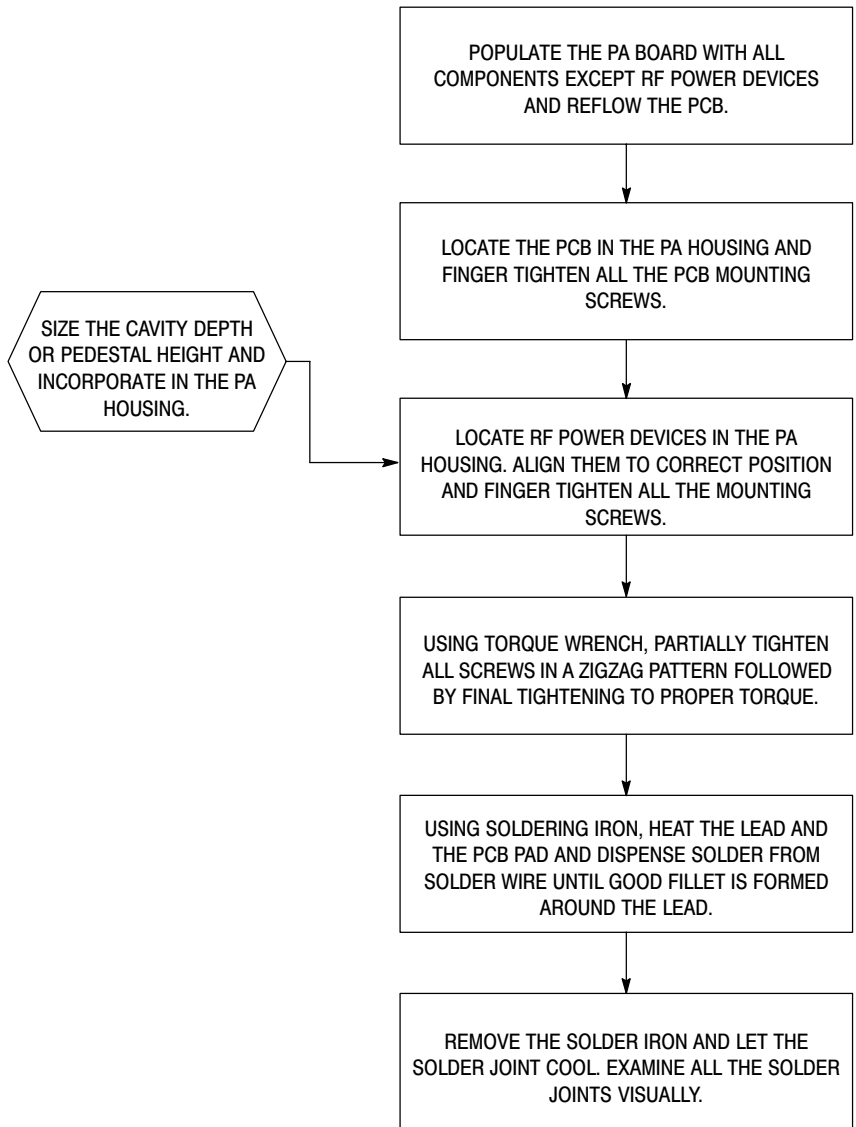

Figure 8. Soldering after Bolt Down Process Flow

At this stage, the device leads are ready to be soldered using a soldering iron or hot bar soldering. In either case, the tip temperature must be hot enough to melt the solder so that it flows, wets the solderable surfaces on the lead and the PCB pads and creates a good solder joint. For the SnPb eutectic alloy (melting temperature of 187°C), the tip temperature

should be $\leq 350^{\circ}\text{C}$. For SnAgCu alloy (melting temperature of 217°C), the tip temperature should be $\leq 400^{\circ}\text{C}$. In all cases,

- The solder tip should not touch the body of the part.
- The plastic temperature should not exceed 300°C, and the soldering time should not exceed 10 seconds.

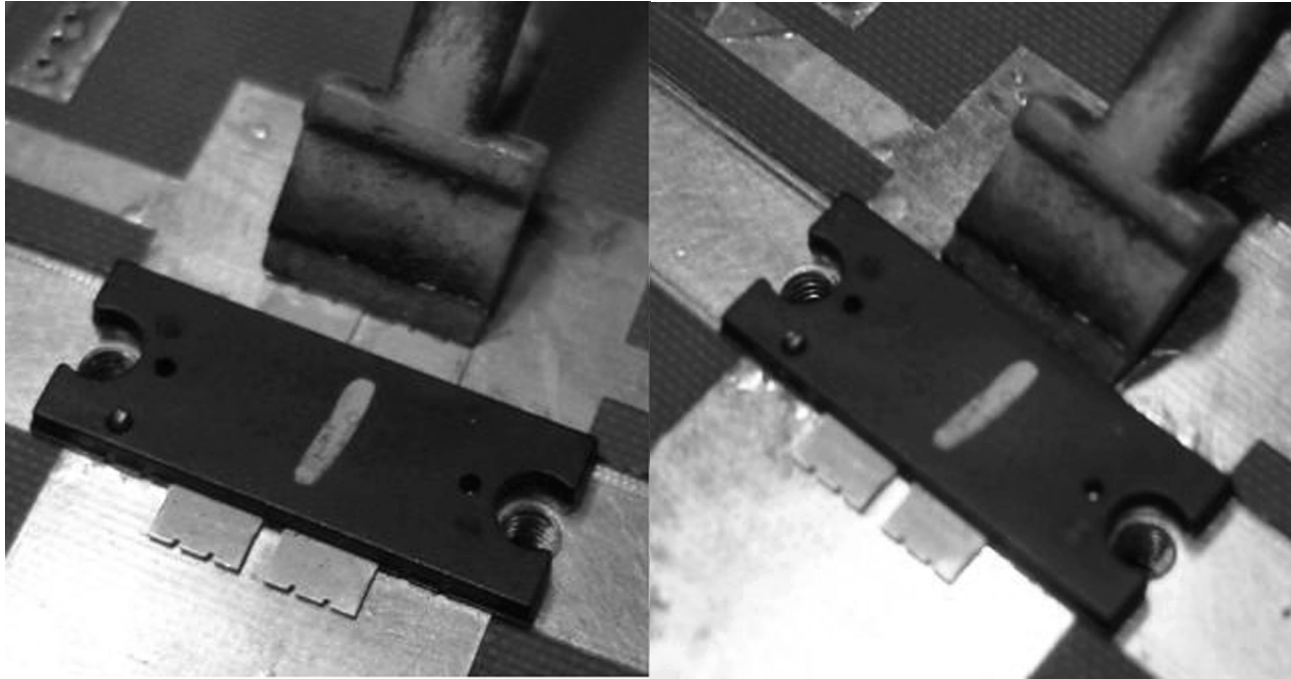

Figure 9. Hand Soldering Do's and Don'ts

In terms of lead deflection, we recommend that the leads should be deflected at the lead tip, not near the base, and the deflection should be restricted to be no more than 0.010" (0.25 mm). Figure 9 shows two pictures. In the picture on the left, the soldering iron is kept away from the body as recommended. In the picture on the right, the soldering iron is touching the body of the package, which is not recommended.

Solder Reflow and Bolt Down

For multi-lead devices as in Case 1329, the lead pitch may be too close for hand-soldering by some assembly operations. If soldering after bolt down is not feasible, the other option is to solder the devices during reflow, as done for surface mount devices, and then proceed with bolting down the PCB assembly into the PA housing. The process flow for the solder reflow and bolt down assembly method is shown in Figure 10. In this type of assembly operation, close attention should be paid to the tolerance stack-up and cavity depth specifications. If necessary, instead of estimating the mean and standard deviation of the dimensional distribution, the distribution should be established by actual measurements. To assure that the height difference between the bottom of the device and the bottom of the PCB match the cavity height specification, it may be necessary to use proper fixturing.

In this method, the solder paste is screen printed on the top surface of the PCB. For multi-lead devices, such as Case 1329, the drain lead is quite wide and may require special care

in terms of the screen opening design. Typically, assembly houses have design rules for the screen opening design to accommodate more uniform solder print thickness. In some instances, the pad may have to be divided in more than one opening to dispense the proper amount of solder paste.

After the PCB is screen printed with solder paste, the PCB is populated by using pick and place equipment and/or chip shooters to add all the components. RF power devices are provided in a standard tape and reel, in which a single device is located in an individual pocket of the tape. The pick and place machine should be used to pick the device out of the tape and place it on the PCB in the opening or slot.

After the PCB is populated, it is sent through a standard reflow furnace. Solder paste manufacturers typically provide the reflow profile requirement for their paste. In the reflow operation, the whole assembly is first heated to a preheat temperature that is 30°C to 50°C below the solder melting temperature and held at that temperature from one to three minutes. During this time, the binder in the paste is burned off, and the flux is activated. After that, the temperature is increased gradually to a peak temperature past the melting temperature of the solder, and then the temperature is ramped down to allow the solder to cool and the joint to form. Typically, the peak temperature is ~30°C above the melting temperature of the solder. The ramp rate and the belt speed are selected to hold the solder joint above the melting temperature of the solder for anywhere from 60 seconds to 150 seconds.

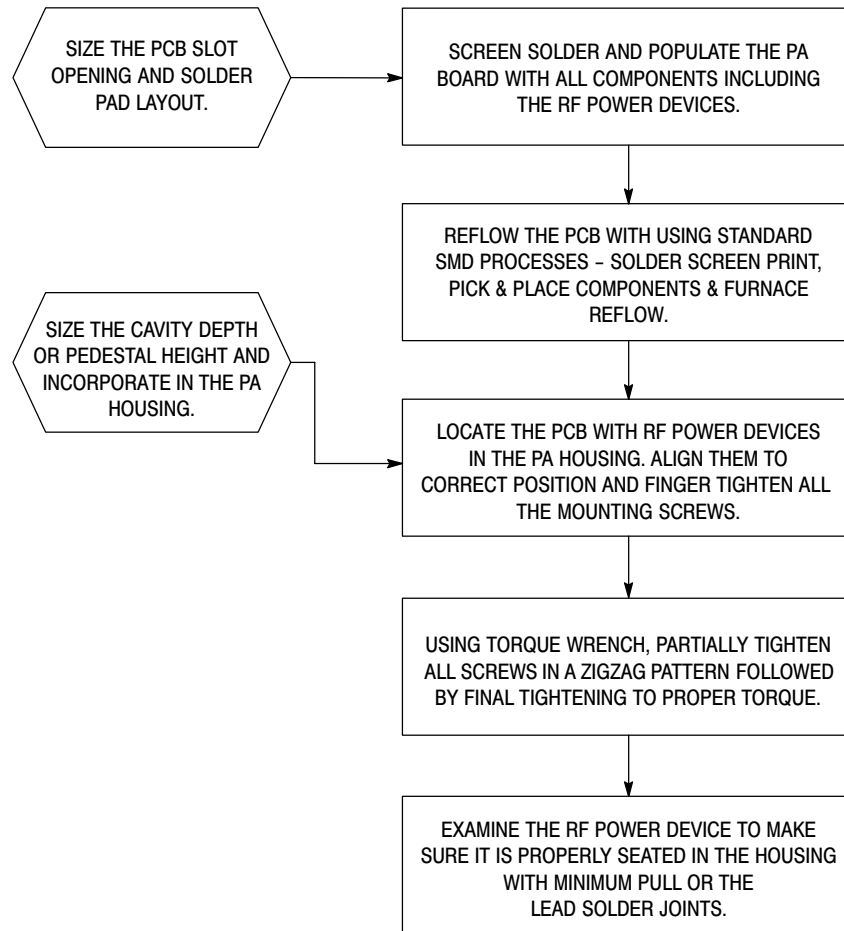

Figure 10. Bolt Down after Solder Reflow Process Flow

Figure 11 shows the typical profile that Freescale used in soldering one of the test assemblies using SnPb eutectic alloys. Similarly, Figure 12 shows the typical profile used for soldering the test assemblies using SnAgCu alloy for Pb-free soldering. These figures are provided only as an example of a typical solder profile. The actual solder profile requirements should be provided by the solder paste supplier.

Since high power RF devices are reflowed on the PCB with all other components, Freescale does not recommend that the PCB should be washed to remove the flux. We recommend that solder paste with only NO CLEAN flux should be used. The OMP packages are not as susceptible to the PCB cleaning operation as are the AC packages.

After the PCB reflow step, the PCB with high power RF devices is ready for assembly in the PA housing. First, the interface pads are located in the appropriate cavity of the PA housing. The PCB with RF devices is put into the housing with the devices aligned to their appropriate place in the PA housing. After the devices and the PCB are aligned to the housing, all the bolts with flat and lock washers are inserted and finger tightened. All the bolts are partially tightened in a zigzag pattern with the use of a torque wrench. After the RF devices and the PCB are fairly secured, all the bolts are tightened to the full specified torque value, again in a zigzag pattern.

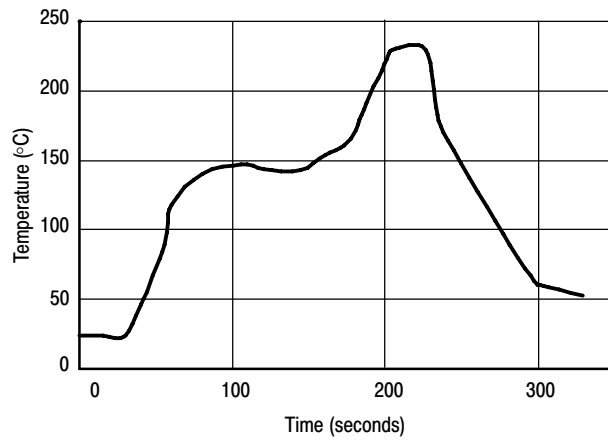

Figure 11. Solder Reflow Profile for SnPb Eutectic Alloys

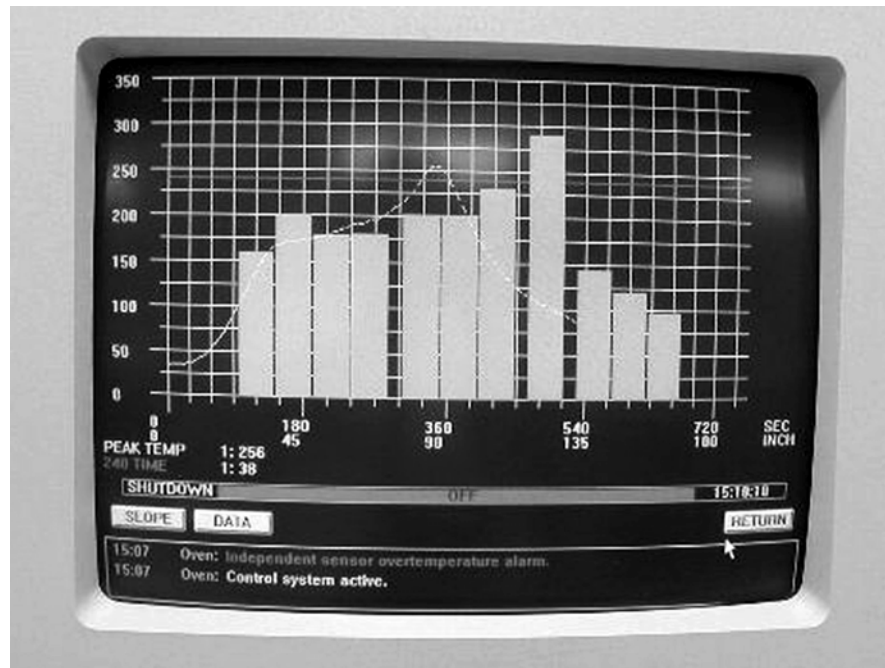

Figure 12. Solder Reflow Profile for SnAgCu Pb-Free Alloys

RELIABILITY TESTING AND RESULTS

So far we have presented two possible ways to assemble high power RF devices in OMP packages into the PA assemblies. The method described here covers both the hand assembly process as well as a more automated process. To validate that the process will yield a reliable assembly, we put some parts through power and thermal cycling and examined the solder joint. The assemblies for power cycling were assembled with circuit elements to power the devices in the DC mode. The assemblies for the temperature cycling were just mechanical assemblies without any electrical circuit elements.

Figure 13 shows the PCB and the RF device soldered to the PCB and with both of them bolted to an aluminum pallet. The multi-lead device (Case 1329) was soldered to a Rogers 4330 PCB using SnAgCu solder alloy. The pallets were mounted on

a finned heat sink to dissipate the heat. During the power cycling, the devices were powered in the DC mode, in which all the input power is dissipated as heat, thus increasing the device temperature. The device temperature is monitored with a thermocouple attached on top of the device. When the device junction reaches 175°C, the power is turned off, and the fans are turned on to blow air on the finned heat sink. When the device temperature falls below 75°C, the fans are turned off, and the power is turned back on. This power on/off cycling was continued until the assemblies were put through 1,000 power on/off cycles. After 1,000 power cycles with the device experiencing minimum 100°C temperature excursions during each cycle, the device solder joints were examined using ultrasonic as well as visual examination. During the solder joint examination, no solder cracking was detected. One of the devices was randomly selected and the solder joint on the three

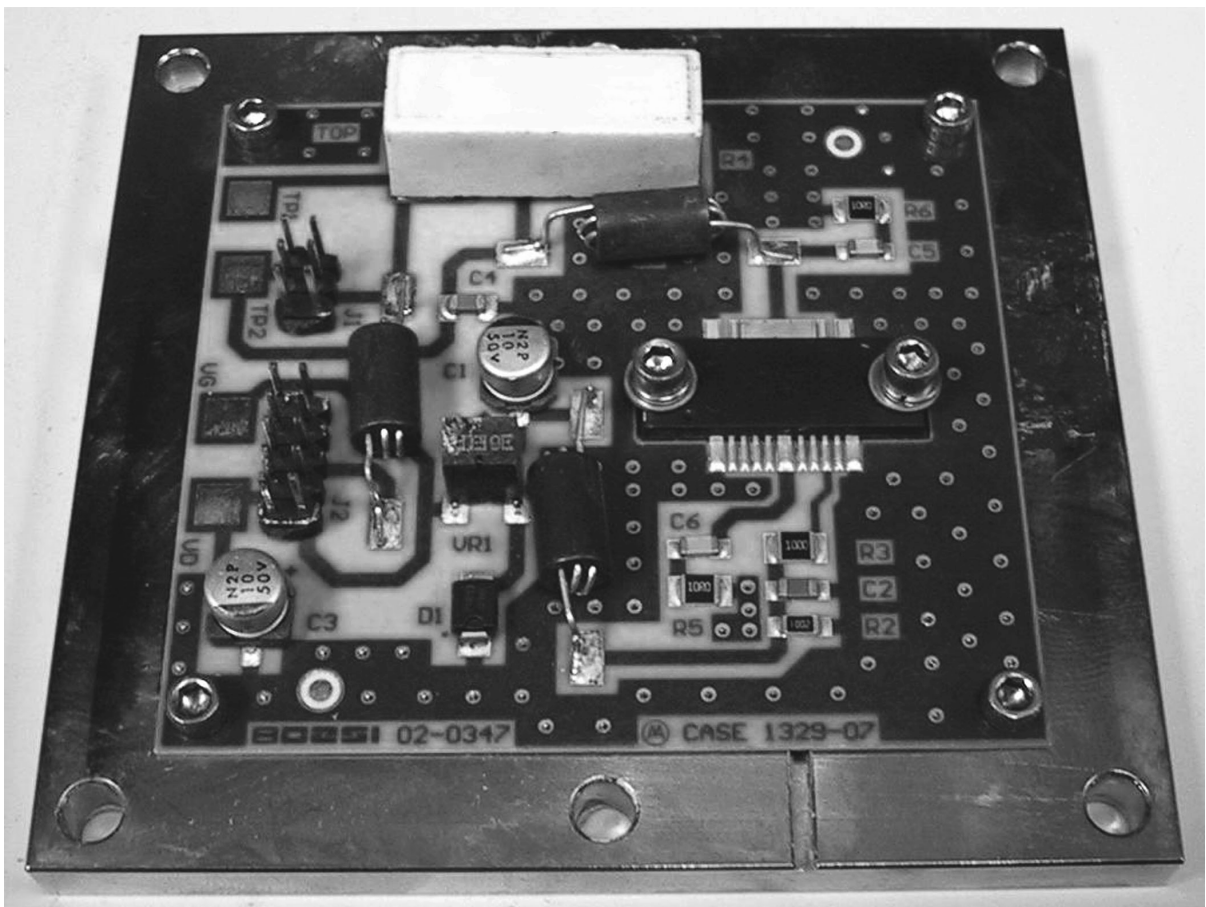

Figure 13. Power Cycling Test Pallet

different leads were cross-sectioned. Figure 14 shows the cross-sections of the solder joints indicating that there is no sign of solder cracking.

Similar to power cycling, four other aluminum pallets with PCBs having eight devices were assembled and used for temperature cycling. Figure 15 shows two different pallets. The pallet on the left shows two-leaded devices (Case 1337) which were soldered using SnPb solder to a two-layer Rogers 4330 PCB. The pallet on the right shows multi-leaded devices (Case 1329) which were soldered using SnAgCu solder to a

two-layer Rogers 4330 PCB. The devices were soldered first and then bolted to an aluminum plate with a cavity. The assemblies were then put through a temperature cycling according to JEDEC J-STD-22-A104, condition G. The temperature extremes in the temperature cycling were from -40°C to 125°C. The assemblies were cycled for 1,000 thermal cycles. After 1,000 cycles, the PCB assemblies were examined for solder joint integrity. None of the solder joints showed any solder cracking.

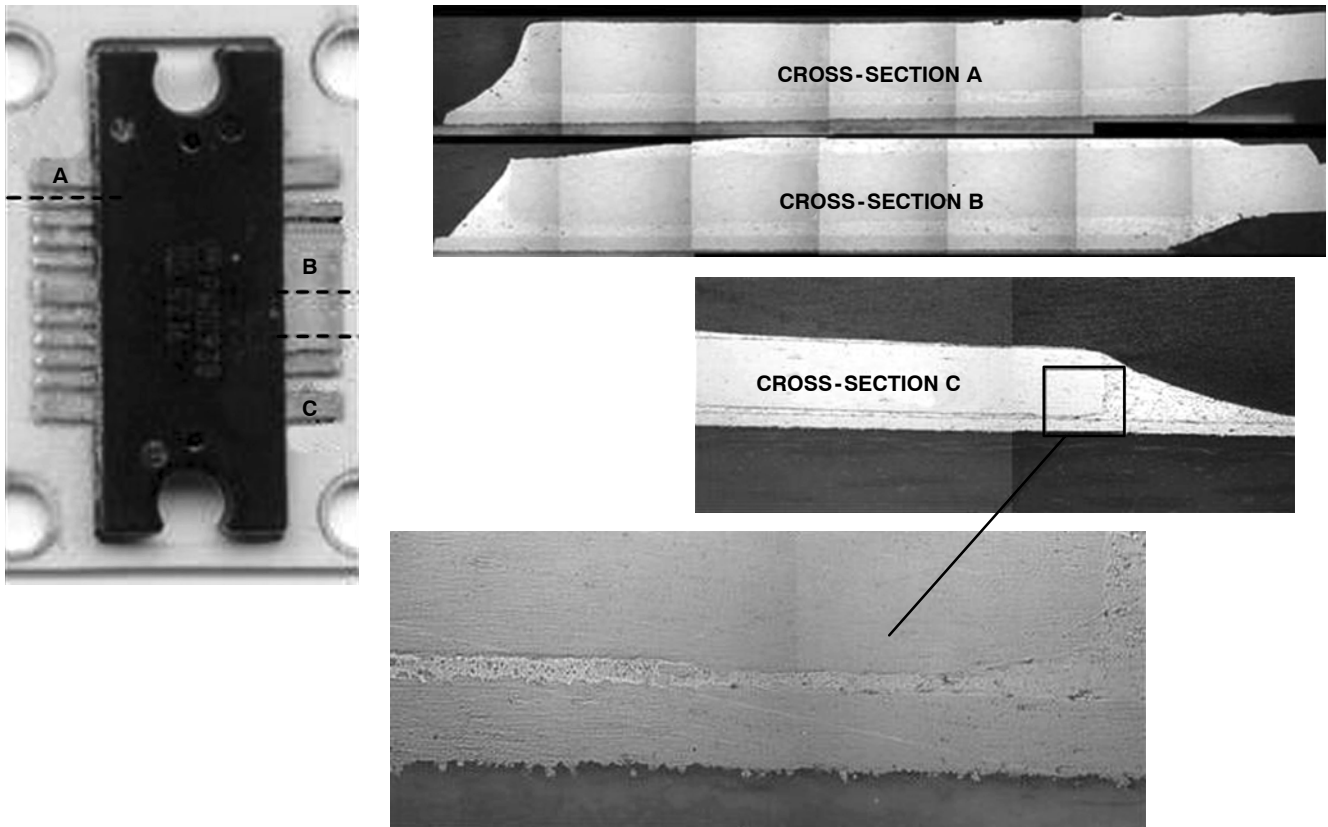

Figure 14. Solder Joint Cross-sections

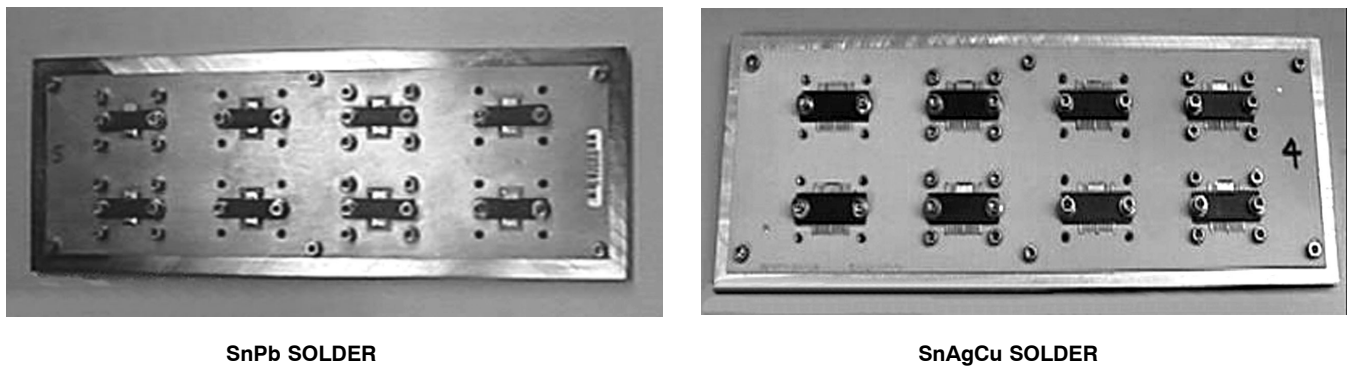

Figure 15. Temperature Cycling Test Pallet

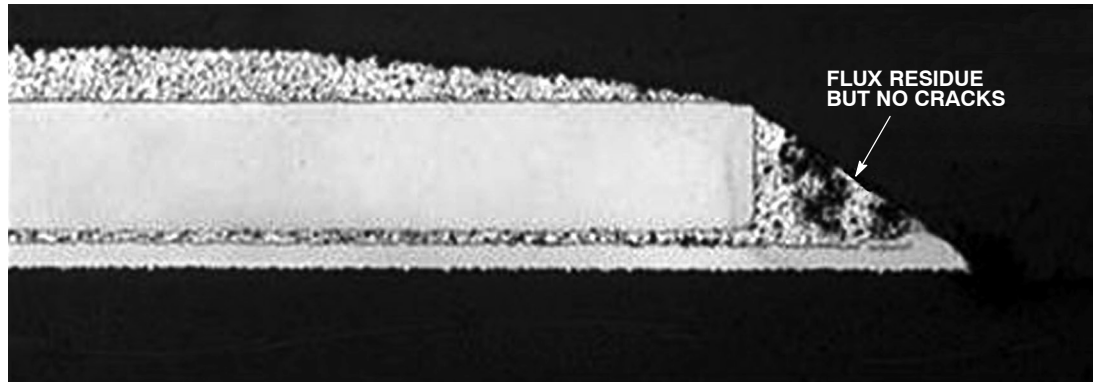
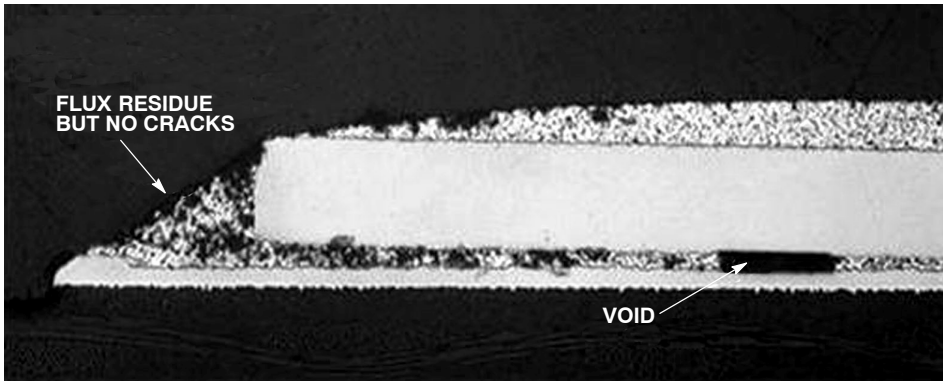

Figure 16. Solder Joint Cross-section Using SnPb Alloy

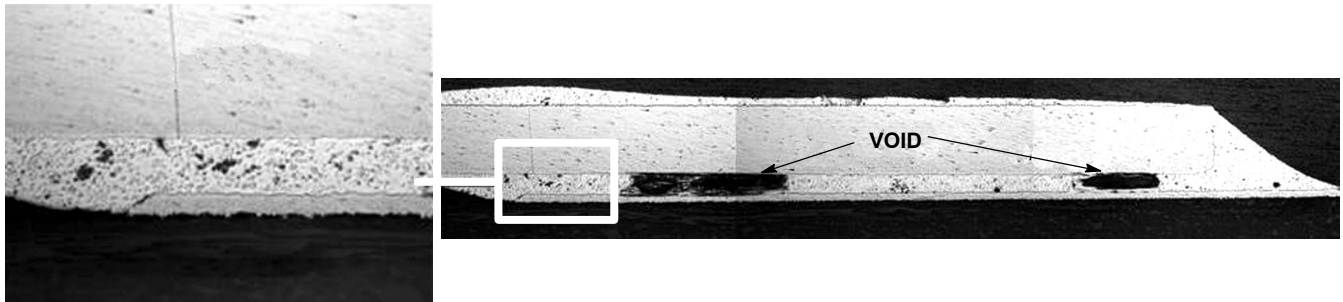

Figure 17. Solder Joint Cross-section Using SnAgCu Alloy

Figure 16 shows the cross-section of the SnPb solder joint, and Figure 17 shows the cross-section of the solder joint at the lead with SnAgCu solder. Both cross-sections represent

a typical solder joint assembly in which there are voids and flux pockets but no cracking in the solder joint.

SUMMARY

This application note has provided a method for assembling RF power devices in over-molded plastic packages and has demonstrated that the resulting assemblies provide reliable solder joints. The main features of the assembly process are as follows:

- A proper dimensioning of the device cavity depth or pedestal height
- A mounting surface that is flat within 0.4 mil/in. (micron/mm) and surface roughness (Ra) of 32 micro-in. (0.8 micron)
- Selection of proper mounting hardware including a #4-40 or M3 screw with a flat washer approximately 0.25" (6.0 mm) in outside diameter and a split washer with approximately 0.209" (5.3 mm) outside diameter
- Selection of proper interface material, electrically conductive such as TGON-805
- Tightening torque of 5 in.-lbs (0.6 N-m)
- Steps for either soldering after bolting down the device or solder reflow followed by bolting down of the device

Finally, it has been demonstrated that the resulting assemblies are capable of withstanding 1,000 temperature cycles from -40°C to 125°C as well as 1,000 power cycles with junction temperature varying from 175°C to 75°C. This application note provides a guide for developing a mounting and assembly process for reliable installation of high power RF devices in over-molded plastic packages in the next assembly. The steps outlined here can be used as a guide for developing a specific structure and a process that is suitable for the design and assembly process for the PA.

Appendix A – PCB Layout Recommendations

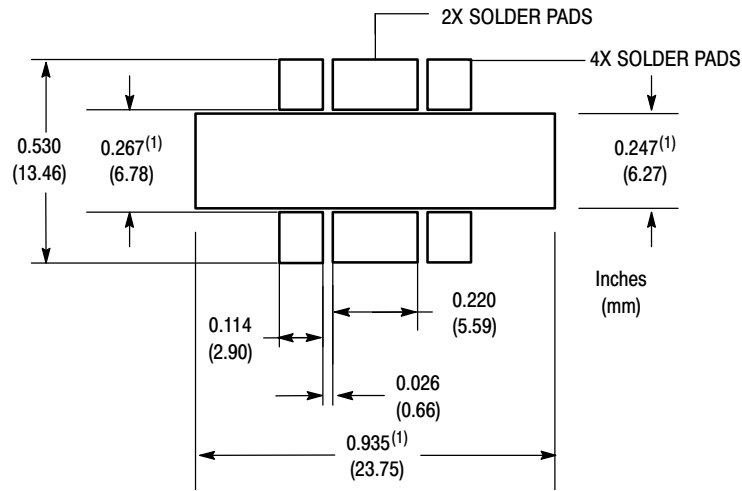

1. Slot dimensions are minimum dimensions and exclude milling tolerances.

Figure A-1. Case 1264A

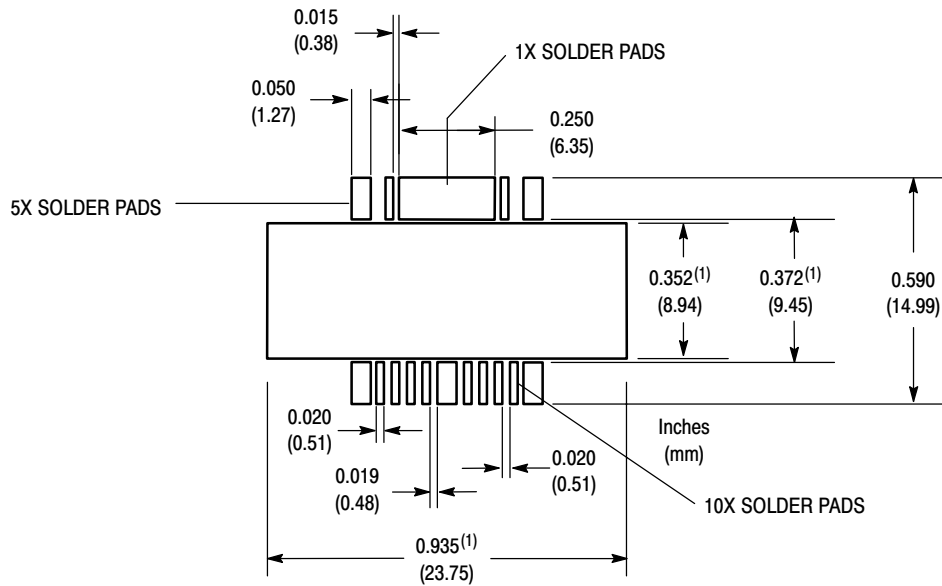

1. Slot dimensions are minimum dimensions and exclude milling tolerances.

Figure A-2. Case 1329

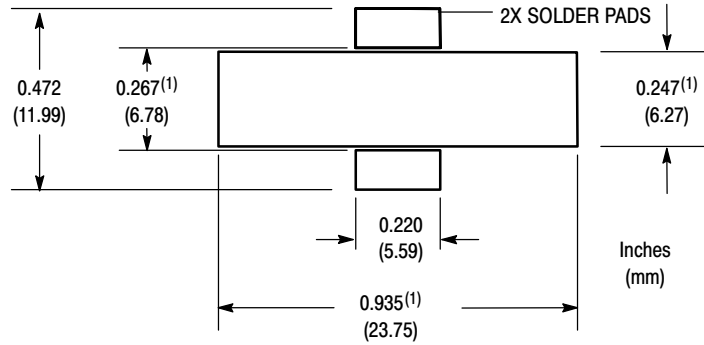

1. Slot dimensions are minimum dimensions and exclude milling tolerances.

Figure A-3. Case 1337

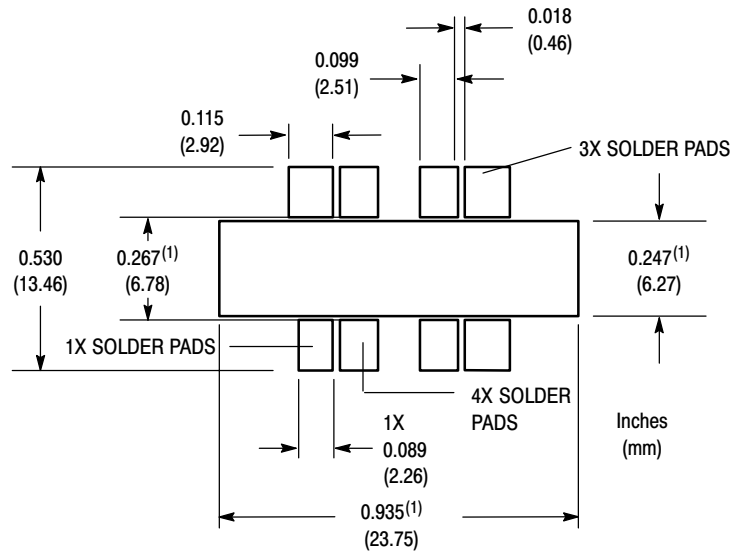

1. Slot dimensions are minimum dimensions and exclude milling tolerances.

Figure A-4. Case 1366A

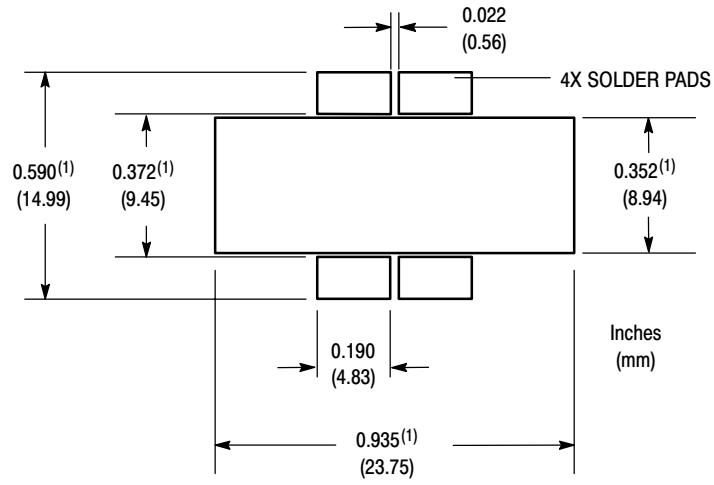

1. Slot dimensions are minimum dimensions and exclude milling tolerances.

Figure A-5. Case 1484

NOTES

How to Reach Us:

Home Page:

www.freescale.com

E-mail:

support@freescale.com

USA/Europe or Locations Not Listed:

Freescale Semiconductor
Technical Information Center, CH370
1300 N. Alma School Road
Chandler, Arizona 85224
+1-800-521-6274 or +1-480-768-2130
support@freescale.com

Europe, Middle East, and Africa:

Freescale Halbleiter Deutschland GmbH
Technical Information Center
Schatzbogen 7
81829 Muenchen, Germany
+44 1296 380 456 (English)
+46 8 52200080 (English)
+49 89 92103 559 (German)
+33 1 69 35 48 48 (French)
support@freescale.com

Japan:

Freescale Semiconductor Japan Ltd.
Headquarters
ARCO Tower 15F
1-8-1, Shimo-Meguro, Meguro-ku,
Tokyo 153-0064
Japan
0120 191014 or +81 3 5437 9125
support.japan@freescale.com

Asia/Pacific:

Freescale Semiconductor Hong Kong Ltd.
Technical Information Center
2 Dai King Street
Tai Po Industrial Estate
Tai Po, N.T., Hong Kong
+800 2666 8080
support.asia@freescale.com

For Literature Requests Only:

Freescale Semiconductor Literature Distribution Center
P.O. Box 5405
Denver, Colorado 80217
1-800-441-2447 or 303-675-2140
Fax: 303-675-2150
LDCForFreescaleSemiconductor@hibbertgroup.com

Information in this document is provided solely to enable system and software implementers to use Freescale Semiconductor products. There are no express or implied copyright licenses granted hereunder to design or fabricate any integrated circuits or integrated circuits based on the information in this document.

Freescale Semiconductor reserves the right to make changes without further notice to any products herein. Freescale Semiconductor makes no warranty, representation or guarantee regarding the suitability of its products for any particular purpose, nor does Freescale Semiconductor assume any liability arising out of the application or use of any product or circuit, and specifically disclaims any and all liability, including without limitation consequential or incidental damages. "Typical" parameters that may be provided in Freescale Semiconductor data sheets and/or specifications can and do vary in different applications and actual performance may vary over time. All operating parameters, including "Typicals", must be validated for each customer application by customer's technical experts. Freescale Semiconductor does not convey any license under its patent rights nor the rights of others. Freescale Semiconductor products are not designed, intended, or authorized for use as components in systems intended for surgical implant into the body, or other applications intended to support or sustain life, or for any other application in which the failure of the Freescale Semiconductor product could create a situation where personal injury or death may occur. Should Buyer purchase or use Freescale Semiconductor products for any such unintended or unauthorized application, Buyer shall indemnify and hold Freescale Semiconductor and its officers, employees, subsidiaries, affiliates, and distributors harmless against all claims, costs, damages, and expenses, and reasonable attorney fees arising out of, directly or indirectly, any claim of personal injury or death associated with such unintended or unauthorized use, even if such claim alleges that Freescale Semiconductor was negligent regarding the design or manufacture of the part.

Freescale™ and the Freescale logo are trademarks of Freescale Semiconductor, Inc. All other product or service names are the property of their respective owners.
© Freescale Semiconductor, Inc. 2006. All rights reserved.